

# HARVESTER R23

## Technical characteristics

<b>Yield per hectare</b>	
<b>Engine</b>	DEUTZ 4 cylinders 3.6 liters - (100 Kw) 136 hp at 2200 t / mm Stage V Automatic diet management (reduction of consumption) Regulated cooler (reduction in consumption & support hot temperatures) Automatic cooler cleaning
<b>Transmission</b>	Self-propelled hydrostatic advancement SAUER DANFOSS 2 electronic speeds (automotive road + work) 4 driving/steering wheels Very high steering flexibility (Max torque available whatever the speed) Brake in both axles
<b>Tires</b>	Radial tire 425-55 R17
<b>Gasoline Tank</b>	Diesel: 150 lt // ADBLUE 10 lt
<b>OPERATION PICKUP</b>	
<b>Harvesting Pick-up</b>	Cylindrical with rubber tabs Ø1100 mm Lifting front plate and rotor inverter Automated pick-up function.
<b>Harvesting width</b>	2 m
<b>Sweeping width</b>	Up to 5.80m
<b>Lateral blower</b>	Powerful, installed as close as possible to the sweeper, it offers maximum power in a small footprint.
<b>Blower</b>	Adjustable and air flow control on the dashboard. Circular box with 2 fans Ø470 mm
<b>Sorting</b>	1st pre-sorting of impurities by bar chain 2nd sorting of the leaves by ventilation (diffuser over the entire collection width) Smooth reverse leaf conveyor belt 3rd final sorting by bar belt or vibrating grid (space 21 mm)
<b>Hopper</b>	Hydraulic lifting and tilting Hopper level by ultrasonic sensors Volume: 2,100 liters Drain height: 2.90 m
<b>Standard equipment</b>	Closed cabin filtered, air-conditioned Electronic display, control and adjustment of all movements End of row management / All pickup controls with the joystick Hopper equalizer / Leaf evacuator / Hopper filling sensor / xtinguisher
<b>WEIGHTS and DIMENSIONS</b>	
<b>Length</b>	6.93 m to 9.78 (depending on options) (7.37m with a Ø1250 nut sweeper)
<b>Width</b>	2.40 m to 3.13m (depending on options)
<b>Height</b>	2,04m à 2,34m (suiwant options)
<b>Weight</b>	2.04m to 2.34m (depending on options)
<b>OPTIONS</b>	
<b>Options</b>	Lateral satellite sweeper / Crabbing / Support with depth wheels Reinforced filtration / Floating pickup / Counter-rotor....

# HARVESTER R23



**Manufacturer of solutions for the harvest and work of the fruits** 

**A M B Rousset**  
impasse du Tilleul  
38470 BEAULIEU - France



Tél : +33 (0) 4 76 36 73 73  
Fax : +33 (0) 4 76 36 70 82  
E-mail : [export@ambrousset.com](mailto:export@ambrousset.com)  
[www.amb-rousset.com](http://www.amb-rousset.com)





Made in France



Performance and comfort



Adaptable and functional



New design



Latest generation engine



Large harvesting width



Tailor made

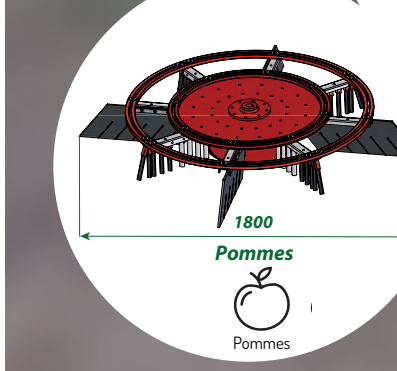
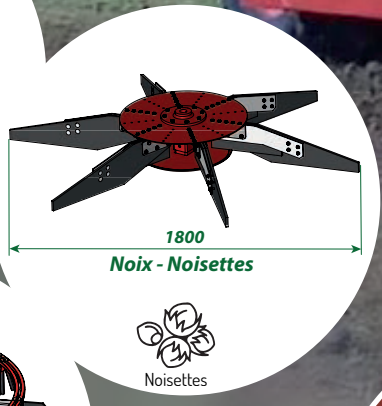
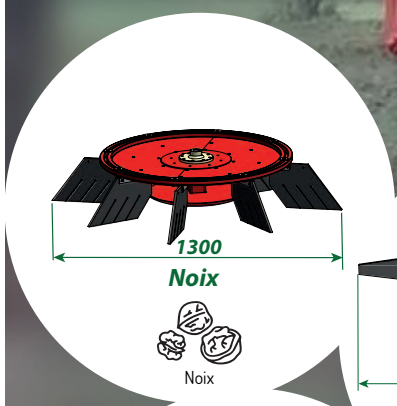
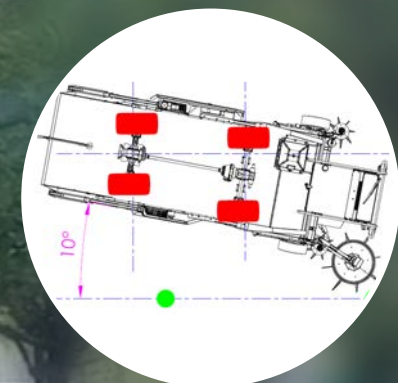
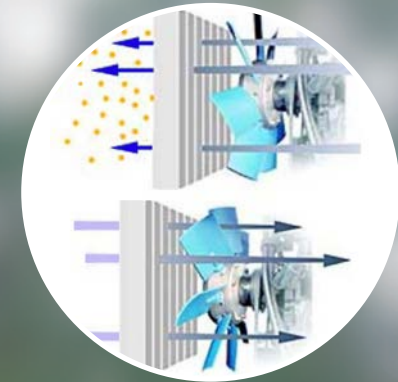
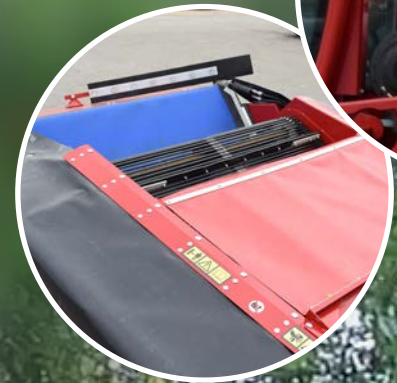
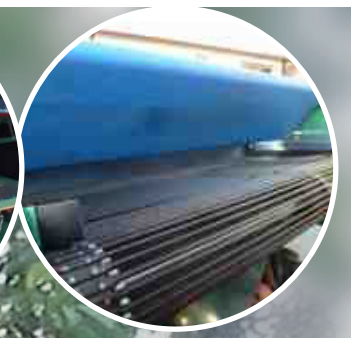

**HARVESTER**  
**R23**